

Experiment #6, Series and Parallel Circuits, Kirchoff's Laws

1 Purpose

Our purpose is to explore and validate Kirchoff's laws as a way to better understanding simple DC circuits.

2 Introduction

As we learned last week an electrical circuit is any continuous path or array of paths along which current may flow. A circuit usually contains a battery or other sources of EMF to create the current. Without a source of energy to drive the circuit no current will flow. Between the terminals of our power source can be any combination of elements through which the electrons may pass; anything from a single wire to a complicated collection of wires, tubes, transistors, and circuit elements.

Whatever the elements that make up the circuit there are some simple rules that must be obeyed. Two of these rules are Kirchoff's laws regarding current and voltage.

Since, as far as we know, charge can be neither created nor destroyed, if we pick a single point in a circuit all of the charge that flows into that point must also flow out of it in a steady state, or unchanging situation. Put in terms of currents Kirchoff's law derived from the conservation of charge states that at a given node (point in the circuit) the sum of the currents flowing into and out of that node will be zero. This is shown schematically in figure 1 where the sum of the three current flowing into and out of the node signified by the black dot adds to zero, $I_1 + I_2 + I_3 = 0$. Note in this case two of the currents are negative, that is to say they flow out of the node.

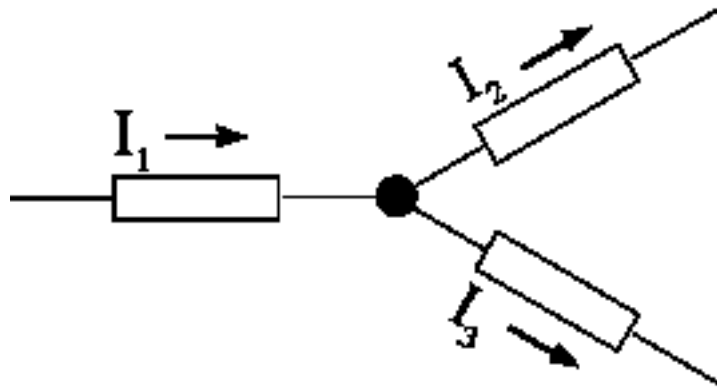

Figure 1.

Kirchoff's law for voltages in a circuit is a consequence of the fact that the electric field exerts a force which is conservative. Thought of in terms of potential energies, the potential energy of a charge at a particular point in space does not depend on the path the charge took to get to that point. Since the potential energy of a charge in a circuit is its charge, Q , times the voltage at the point in the circuit, V , the sum of the voltages measured around any loop in a circuit must add to zero. Otherwise, if the charge went around that loop its energy would be changed when it returned to its starting point. This is shown schematically in Figure 2. Here the sum of the voltages will be zero, $V_{a-b} + V_{b-c} + V_{c-d} + V_{d-a} = 0$. Assuming that the left hand node "a" is at the higher potential V_1 , V_2 and V_3 would be positive and V_{d-a} (V_{emf}) would be negative as the voltages are measured counterclockwise. In this lab, $V_{emf} = 10.00V$ will be the power supply that is driving the circuit. This yields:

$$V_1 + V_2 + V_3 - 10.00\text{V} = 0, \text{ or } V_1 + V_2 + V_3 = 10.00\text{V} = V_{\text{emf}}$$

$$IR_1 + IR_2 + IR_3 = 10.00\text{V} = V_{\text{emf}}$$

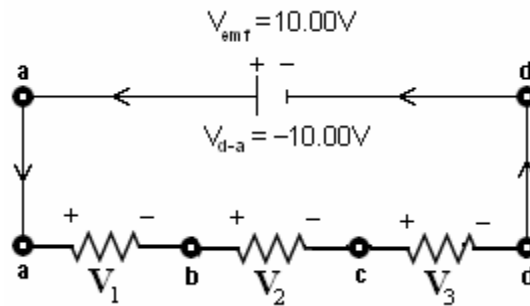

Figure 2

Kirchoff's laws are important because, if we take all the loops and all the nodes in a complicated circuit and apply Kirchoff's laws to them then we end up with a series of algebraic equations which can be solved to uniquely determine all of the voltages and currents in our problem.

3 Experimental Apparatus and Procedure

3.1 Apparatus

1. Hampden DC power supply.
2. Fluke 8000A digital volt-ohmmeter (to be used for voltage and resistance measurements).
3. Fluke 75 digital multi-meter (to be used for all current measurements).
4. Carbon resistors. The color code for determining the resistance of carbon resistors to within 5-10 percent will be explained in class.

If you are curious, read the manuals concerning the operation of the power supply and the digital meters or read the short description in the appendix.

Direct Resistance Measurements with a Digital Ohmmeter.

3.2.1 Resistance in Parallel and Series

1. Measure the resistance of the carbon resistors R_1 , R_2 , R_3 directly using the digital voltmeter (Fluke 8000 A) set to measure resistance in ohms (Ohms function switch setting) and **on the smallest range possible for each resistor**.
2. Connect the resistors in parallel and series and measure the equivalent parallel and series resistance of these networks. Compare your measured values with the theoretical values calculated from the following formulas:

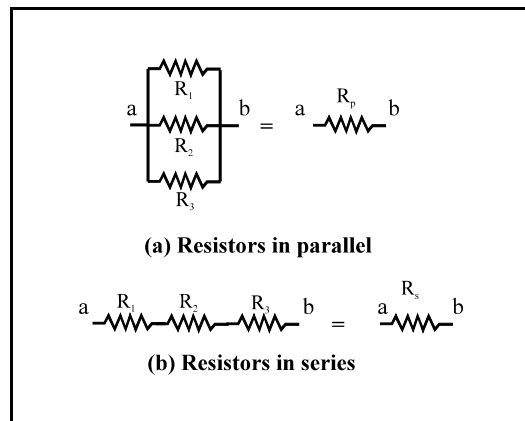

a. Equivalent parallel resistance:

$$1/R_p = 1/R_1 + 1/R_2 + 1/R_3$$

b. Equivalent series resistance:

$$R_s = R_1 + R_2 + R_3$$

3.2.2 Kirchoff's Voltage Law

Assemble the series circuit using three carbon resistors as shown in the figure to the right. Connect the power supply across this network with the milliammeter (Fluke 75) in series. The milliammeter (current meter) measures the current (1 mA = 0.001 A, where A = ampere). Set the power supply to $V_{emf} = 10.00$ V. Record the current I in the circuit and measure the voltage drop V across each resistor using the voltmeter (Fluke 8000A).

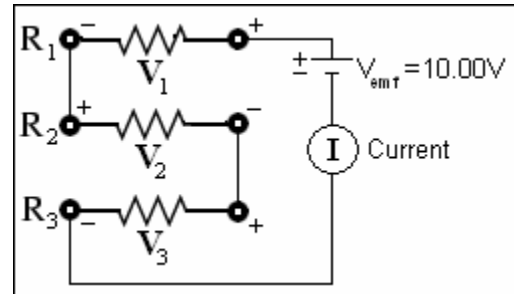

3.2.3 Kirchoff's Current Law

In this section we will be studying Kirchoff's current law. The circuit we will be examining is shown to the right. The node we are going to explore is the point where the three resistors connect. Because we need to insert the current meter in series with each leg of the circuit of interest there will be a series of measurements with the ammeter in different place in the circuit. All measurement will be made with the same voltage, 5.00 volts, applied to the circuit.

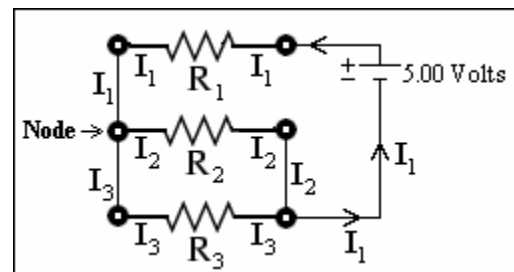

First, insert the ammeter between the end of the first resistor and the low side which is the node. Record the current running through the first resistor. Second, insert the ammeter between the second resistor and the node. Record the current running through the second resistor. Finally, insert the ammeter between the third resistor and the node. Record the current running through the third resistor. Now, with the ammeter out of the loop, measure and record the voltage drop across each of the three resistors. All voltage measurements should be made with the node as the low side of the potential.

4 Calculations and Analysis

4.1 Analysis of Resistance in Parallel and Series

1. Use percent difference to compare the experimental and theoretical value of R_p .
2. Use percent difference to compare the experimental and theoretical value of R_s .

4.2 Analysis of the simple series circuit

1. Use percent difference to compare the experimental value of the current in the circuit with the theoretical value calculated using the equation $I = V/R_s$, where R_s is the equivalent series resistance of the network as directly measured above.
2. Use percent difference to compare the experimental value of the voltage drop across each resistor with the theoretical value calculated using the formula $V = IR$ (the experimental value for I and the measured resistance of each resistor).
3. Verify Kirchoff's second law, that the algebraic sum of the voltage drops around the circuit in a complete loop is zero. Note that the power supply is a source of EMF so that the current flows through the power supply from negative to positive terminal. Thus, denoting the power supply EMF in volts by V_{emf} , Kirchoff's second law can be written.

$$V_{emf} = V_1 + V_2 + V_3$$

$$V_{emf} = IR_1 + IR_2 + IR_3$$

Where the V 's refer to corresponding measured voltage drops across each of the three resistors in the circuit as indicated in Figure 2.

4.2 Analysis of the Kirchoff Current Law.

1. Use percent difference to compare the measured value of the current in the circuit with the theoretical value calculated using the equation $I_1 = V_1/R_1$ where R_1 is the resistance of the first resistor as directly measured above. Do the same for the second and third resistor.
2. Verify Kirchoff's current law, that the algebraic sum of currents in a node is zero. Note that one current flows into the node and two flow out.

5 Questions

1. Did you verify the Kirchoff's voltage law for the simple series circuit which you constructed? Explain how this was shown. If the verification was not exact, how large was the deviation.
2. Did you verify the Kirchoff's current law for the circuit shown in the lab write up? Explain how this was shown. If the verification was not exact, how large was the deviation.

6 Conclusion

This section should have a clear statement of the results of the experiment and the extent to which the results are in agreement with the theory being tested. When the experiment results in a measurement of a constant, e.g., the acceleration of gravity, g , compare it with its established handbook values. Use percent difference for this comparison.

To make this comparison meaningful, you should include the impact of the experimental error on your results. This includes errors in plotting and reading linear graphs when determining their slope and intercept. In addition, please include a statement of what you have learned, a critique of the experiment, and any suggestions you have which you think could improve the experiment or the lab handout.

Instrumentation

1. The **DC Voltmeter** measures the voltage difference between two points to which its terminals are connected. The voltmeter is always connected **in parallel** to the part of the circuit across which the potential difference is to be measured (Figure A1). In this experiment the Fluke 8000A multi-meter is used to measure voltage differences.

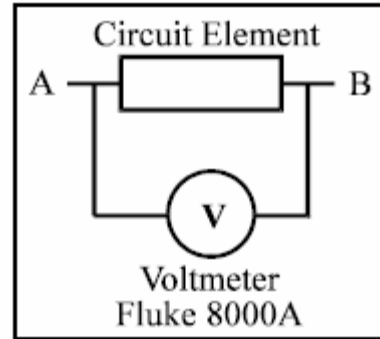

Figure A1: Voltmeter.

2. The **DC Milliammeter** measures the electric current between any two points to which its terminals are connected. To measure the current in any part of the circuit, the circuit must be broken at that point and the ammeter must be inserted in the gap with loose ends connected to its terminals, i.e., the meter is connected **in series** with that part of the circuit where the current is to be measured (Figure A2). The Fluke 75 battery powered multi-meter is used to measure the current in milliamperes (mA). (1 mA = 0.001 A)

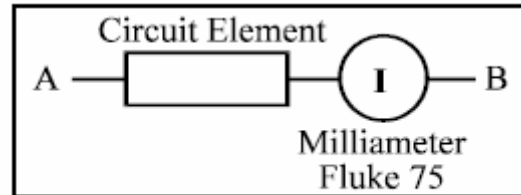

Figure A2: A milliammeter

3. Connecting wire leads. Assumed to be made of a good conducting material, e.g., a metal such as copper, and of a large enough cross-section to have negligible resistance and voltage drop across them.

4. The **DC Power supply** is a device used to supply a constant source of EMF between its output terminals. The electric current flows internally in the power supply from the minus to the plus terminal. In the external circuit it flows from the plus to the minus terminal (Figure A3). The voltmeter on the Hampden supply is not accurate and should not be used to determine the output voltage.

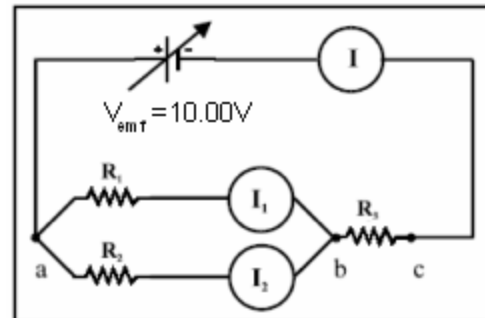

Figure A3: Electrical circuit.

Simply Circuit Data Sheet

1 Individual Resistors

Measured (8000A)

$$R_1 = \underline{\hspace{2cm}}$$

$$R_2 = \underline{\hspace{2cm}}$$

$$R_3 = \underline{\hspace{2cm}}$$

2 Parallel Combination

Experimental: $R_p = \underline{\hspace{2cm}}$

Theoretical: $R_p = [1/R_1 + 1/R_2 + 1/R_3]^{-1} = \underline{\hspace{2cm}}$ (use measured values of R)

Series Combination

Experimental: $R_s = \underline{\hspace{2cm}}$

Theoretical: $R_s = R_1 + R_2 + R_3 = \underline{\hspace{2cm}}$ (use measured values of R)

3 Study of Simple Circuits: Kirchoff's Voltage Law

A. Applied Voltage $V_{emf} = \underline{\hspace{2cm}}$ (10.00 volts) (Enter as a positive value.)

B. Current I

Experimental: $I = \underline{\hspace{2cm}}$ (1 mA = 0.001 A)

Theoretical: $I = V_{emf}/R_s = \underline{\hspace{2cm}}$ (Use Experimental R_s)

C. Voltage drops across the individual resistor. All values should be positive.

Measured (Fluke 8000A) Theoretical $V = IR$ (Use Experimental I & R Measured)

$$V_1 = \underline{\hspace{2cm}} \qquad V_1 = \underline{\hspace{2cm}}$$

$$V_2 = \underline{\hspace{2cm}} \qquad V_2 = \underline{\hspace{2cm}}$$

$$V_3 = \underline{\hspace{2cm}} \qquad V_3 = \underline{\hspace{2cm}}$$

D. Verification of Kirchoff's Law

$$V_{emf} = V_1 + V_2 + V_3$$

Using measured values from part C: $V_{emf} = \underline{\hspace{2cm}}$

Using theoretical values from part C: $V_{emf} = \underline{\hspace{2cm}}$

4 Study of Simple Circuits: Kirchoff's Current Law

A. Applied Voltage = _____

B. Individual Measured Currents and Voltages (Results will be both positive and negative.)

$$I_1 = \text{_____} \quad V_1 = \text{_____}$$

$$I_2 = \text{_____} \quad V_2 = \text{_____}$$

$$I_3 = \text{_____} \quad V_3 = \text{_____}$$

C. Predicted Currents (Use Voltages measured in circuit and resistances that were measured.)

$$I_1^* = \text{_____}$$

$$I_2^* = \text{_____}$$

$$I_3^* = \text{_____}$$

D. Verification of Current Law

Using Measured values; $I_1 + I_2 + I_3 = \text{_____}$

Using Predicted Values $I_1^* + I_2^* + I_3^* = \text{_____}$